 La fuerza que transforma Bolivia	YACIMIENTOS PETROLÍFEROS FISCALES BOLIVIANOS GERENCIA DE REDES DE GAS Y DUCTOS DISTRITO REDES DE GAS ORURO	Anexo 3
	GRAFICOS	Hoja: 1 de 14

GRÁFICOS

1. LETREROS

1.1. LETREROS DE SEÑALIZACIÓN - HOMBRES TRABAJANDO.

(ESTRUCTURA METÁLICA, 850 mm de ancho por 1300 mm de alto)

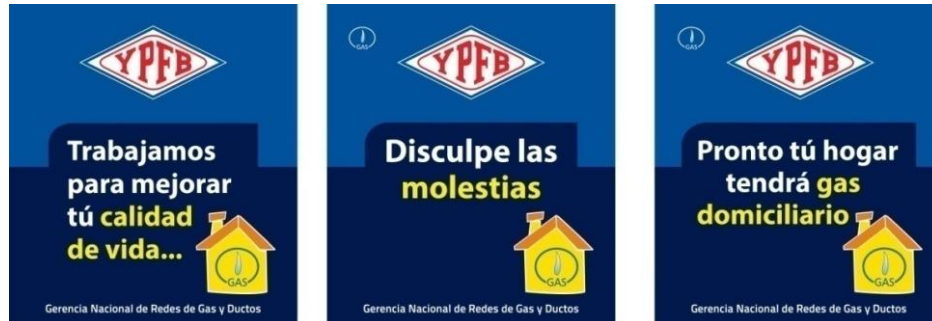

 La fuerza que transforma Bolivia	YACIMIENTOS PETROLÍFEROS FISCALES BOLIVIANOS GERENCIA DE REDES DE GAS Y DUCTOS DISTRITO REDES DE GAS URUO	Anexo 3
	GRAFICOS	Hoja: 2 de 14

1.2. LETRERO DE OBRA. (De acuerdo a especificación, 2,8 m de ancho por 2,0 mm de alto)

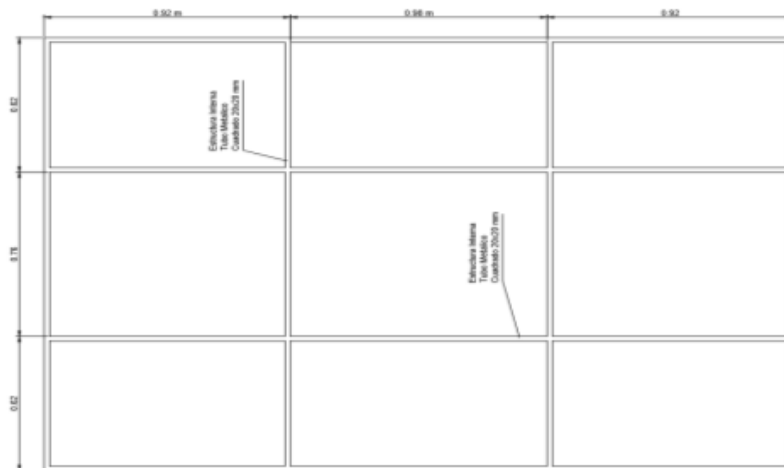



2. EXCAVACIÓN DE ZANJAS

2.1. ACERAS

TERRENO BLANDO Y SEMIDURO

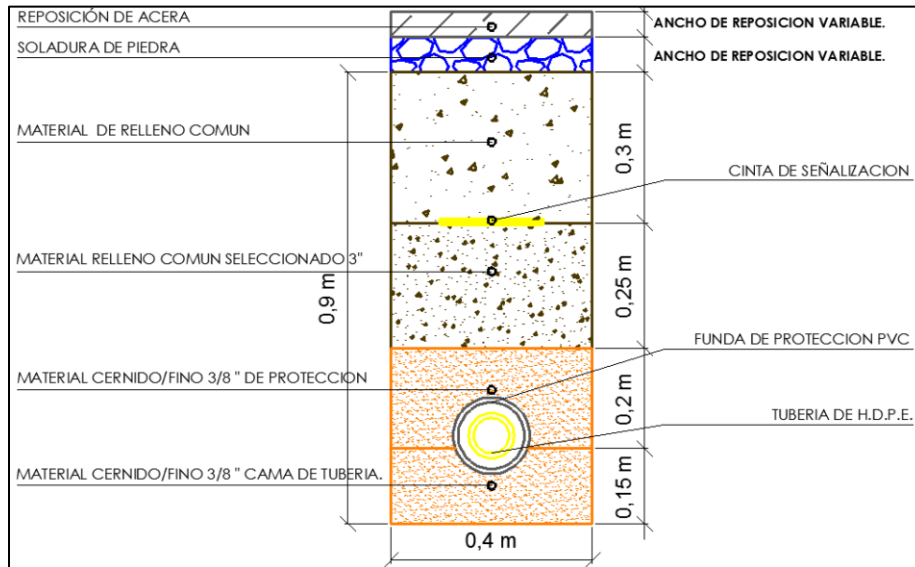

TERRENOS DURES Y ROCOSOS

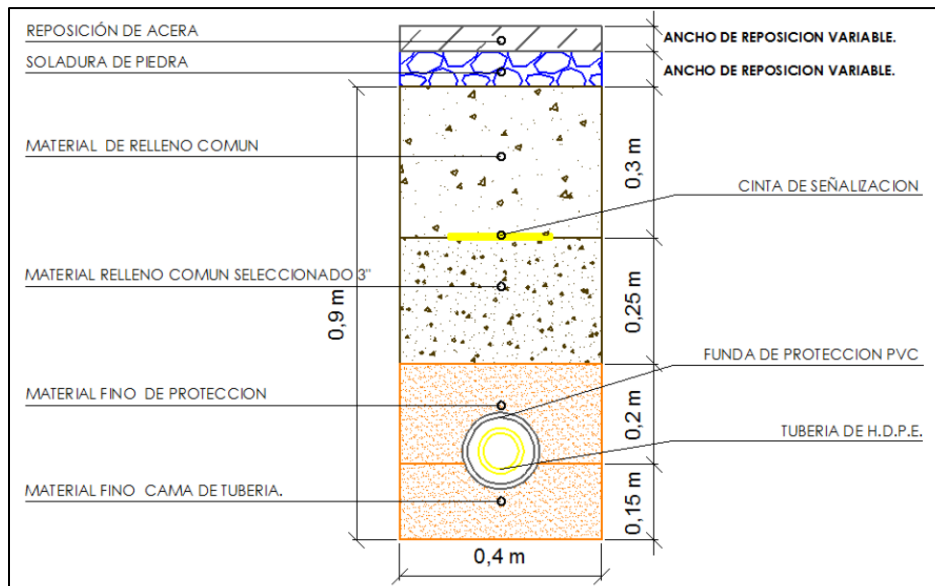



2.2. CALZADAS

TERRENO BLANDO Y SEMIDURO

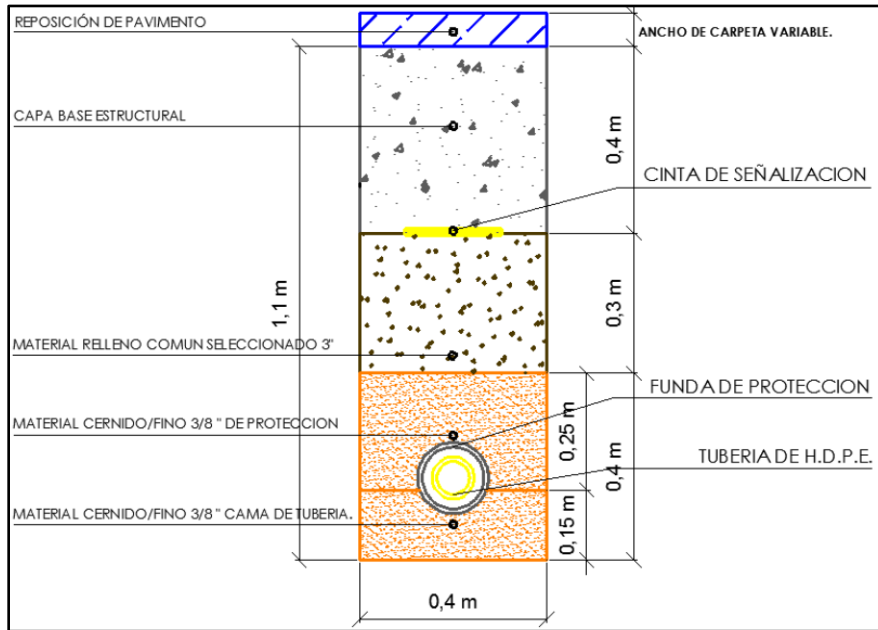

TERRENOS DUROS O ROCOSOS

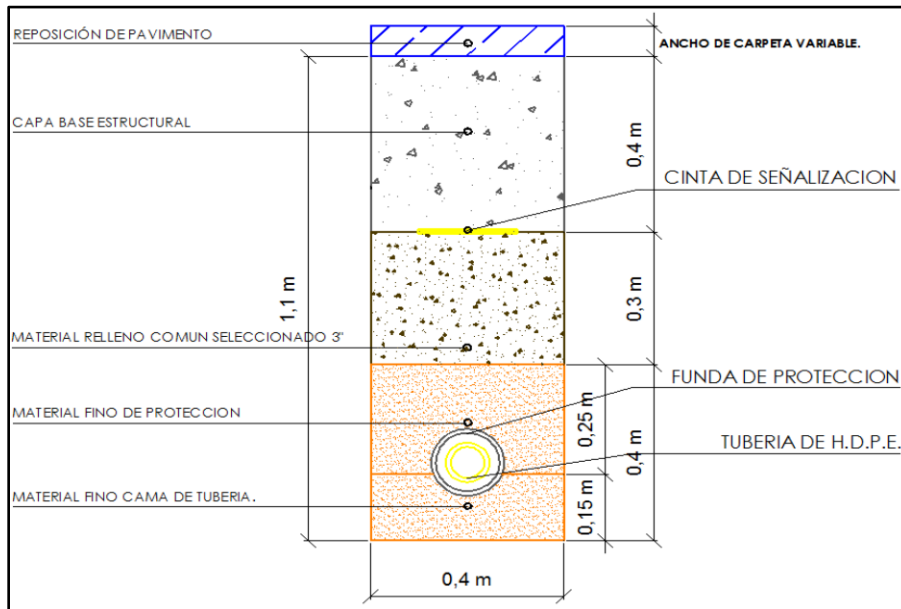



3. MODELOS DE PLAQUETAS DE SEÑALIZACIÓN

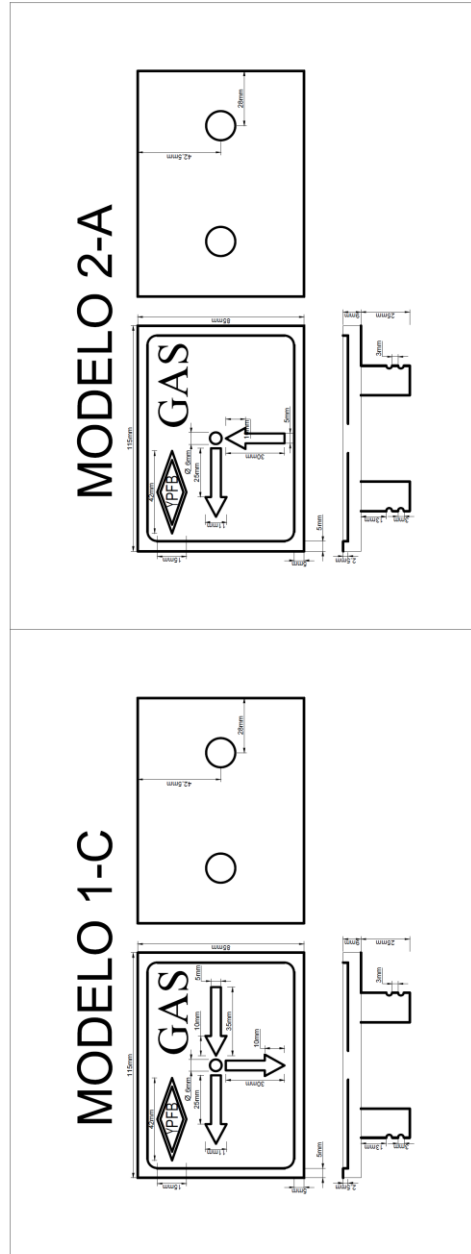
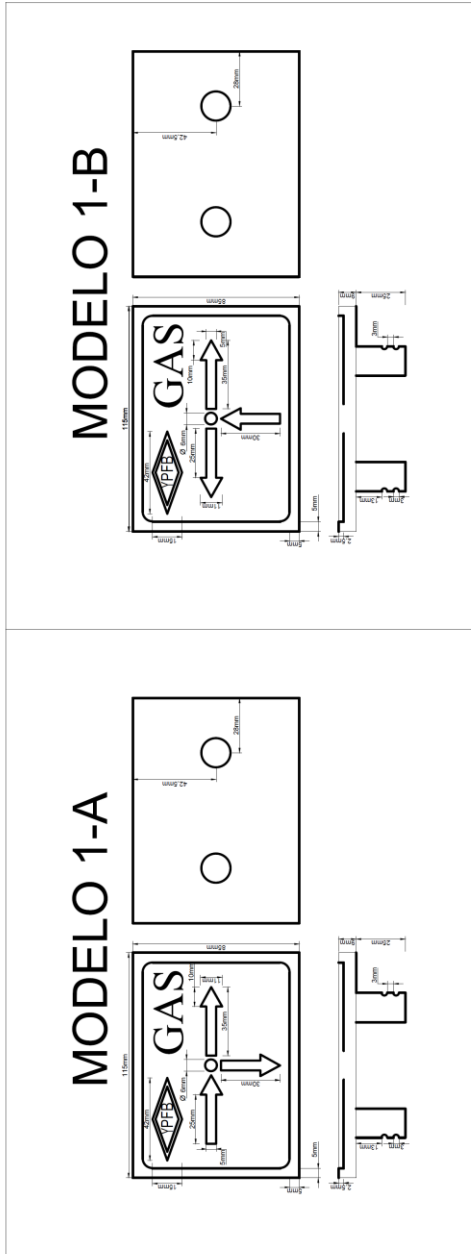



YACIMIENTOS PETROLÍFEROS FISCALES BOLIVIANOS
GERENCIA DE REDES DE GAS Y DUCTOS
DISTRITO REDES DE GAS ORURO

Anexo 3

GRAFICOS

Hoja:
6 de 14

MODELO 3

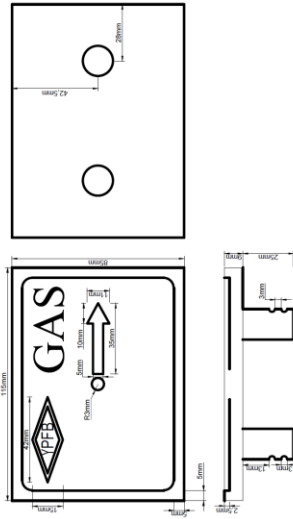

MODELO 2-B

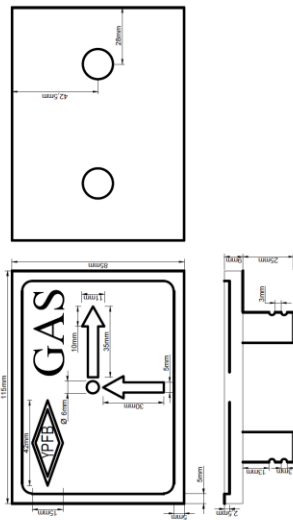

MODELO 4

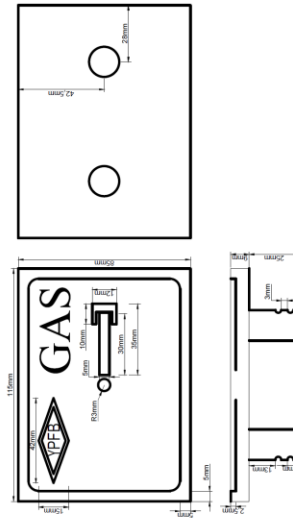



4. OBRAS DE FIJACIÓN DE VÁLVULAS Y SEÑALIZACIÓN HORIZONTAL

4.1 BASES DE HORMIGÓN PARA SEÑALIZACIÓN HORIZONTAL EN COBERTURAS DE EMPEDRADO Y TIERRA

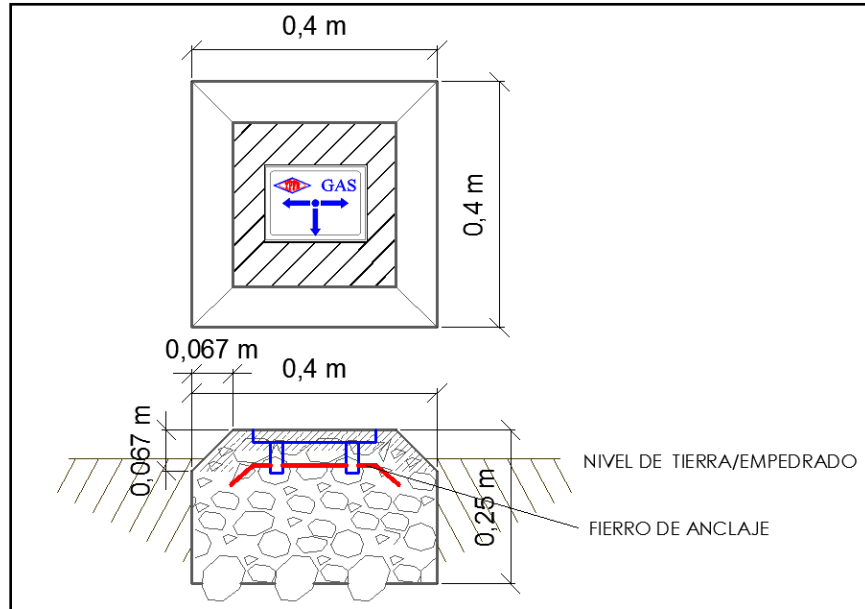

4.2 PLAQUETAS DE SEÑALIZACIÓN HORIZONTAL EN COBERTURAS DE ACERAS DE HORMIGÓN

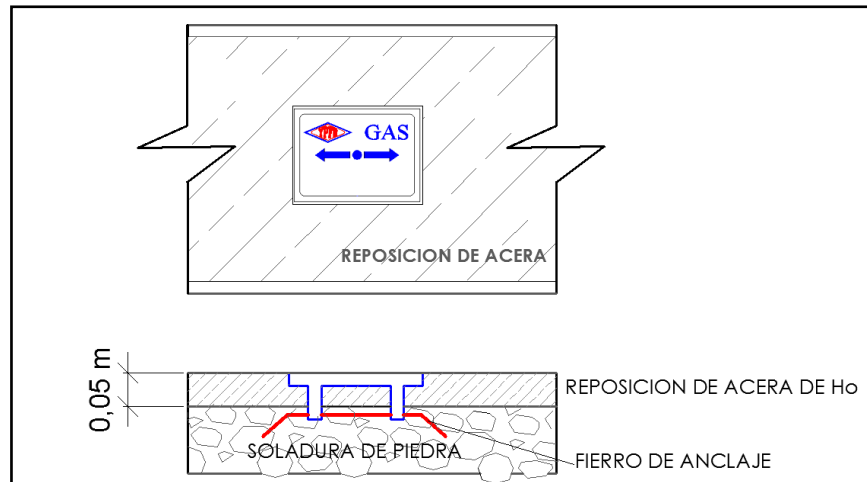

4.3 ESTRUCTURA PARA VÁLVULAS

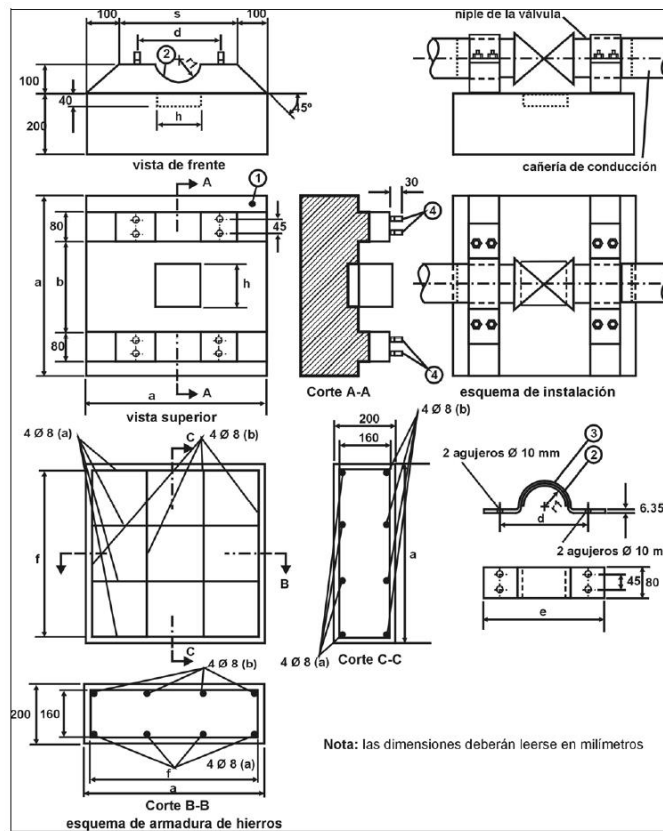
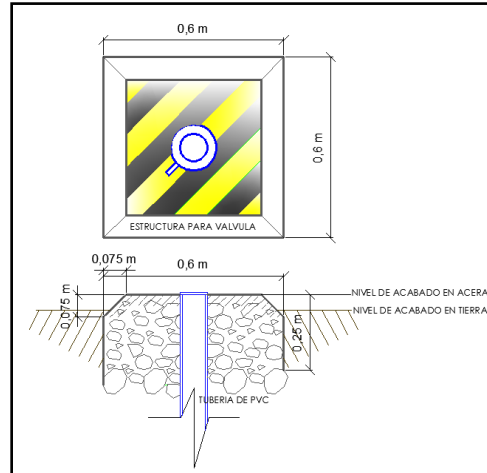



La fuerza que transforma Bolivia

YACIMIENTOS PETROLÍFEROS FISCALES BOLIVIANOS
GERENCIA DE REDES DE GAS Y DUCTOS
DISTRITO REDES DE GAS URURO

Anexo 3

GRAFICOS

Hoja:
9 de 14

BASE DE FIJACIÓN PARA VÁLVULA DE Ø 40 mm

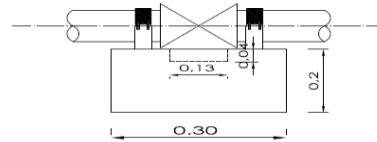
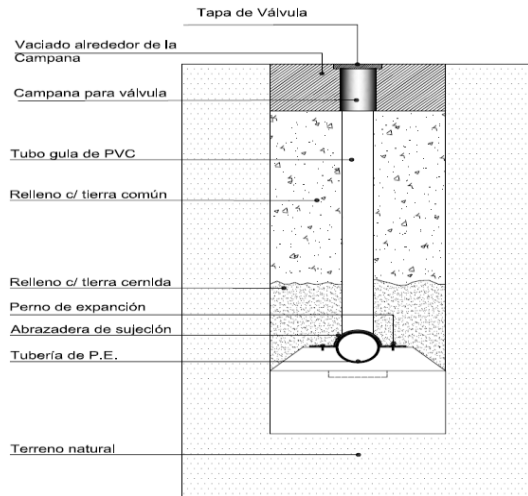

VISTA LATERAL

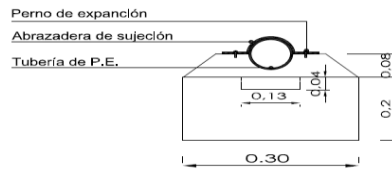

VISTA FRONTAL

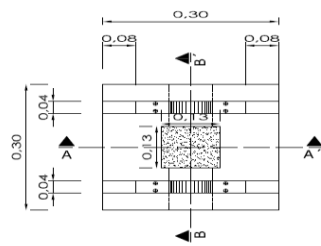

VISTA SUPERIOR

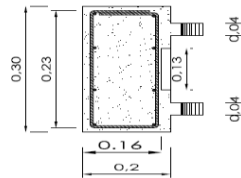

CORTE B - B'

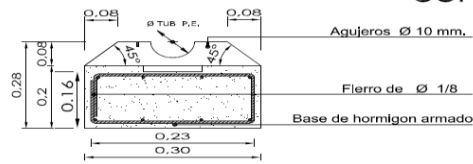

CORTE A - A'



Y.P.F.B.

GERENCIA NACIONAL DE REDES Y DUCTOS

BASE DE FIJACIÓN PARA VÁLVULA
DE POLIETILENO DE Ø 40 mm

FIGURA : N° 1

FECHA: MARZO DE 2012

APROBADO:

ESCALA:
S/E



5. REPOSICIONES EN ACERA

5.1. ACERAS DE HORMIGÓN.

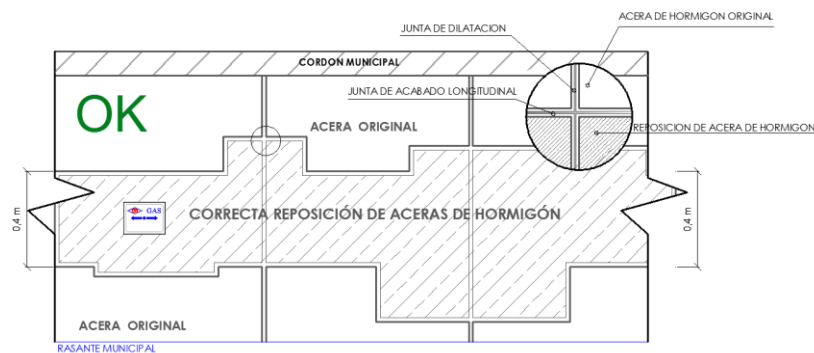
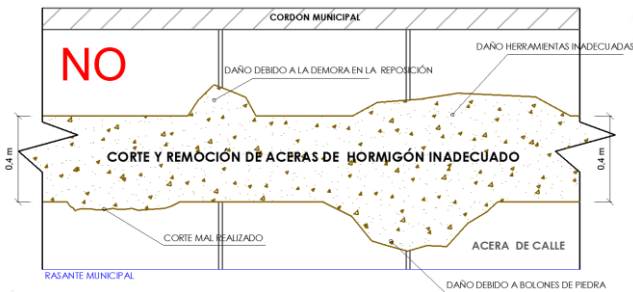
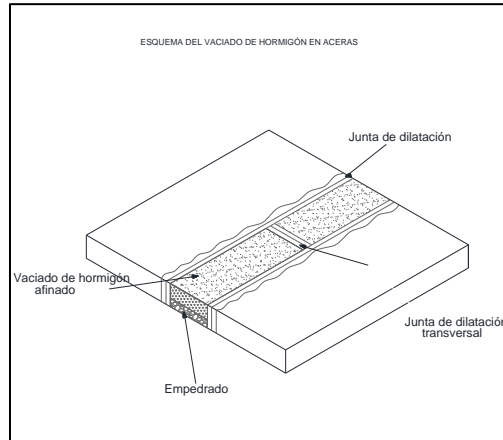



6. TRANSPORTE Y MANIPULACIÓN DE TUBERÍA

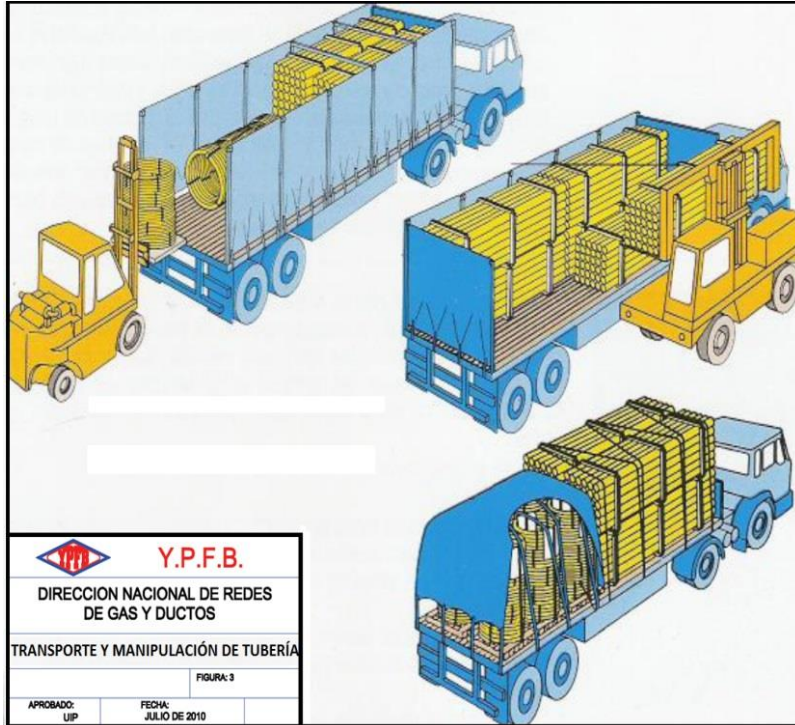

6.1 TRANSPORTE DE TUBERÍA

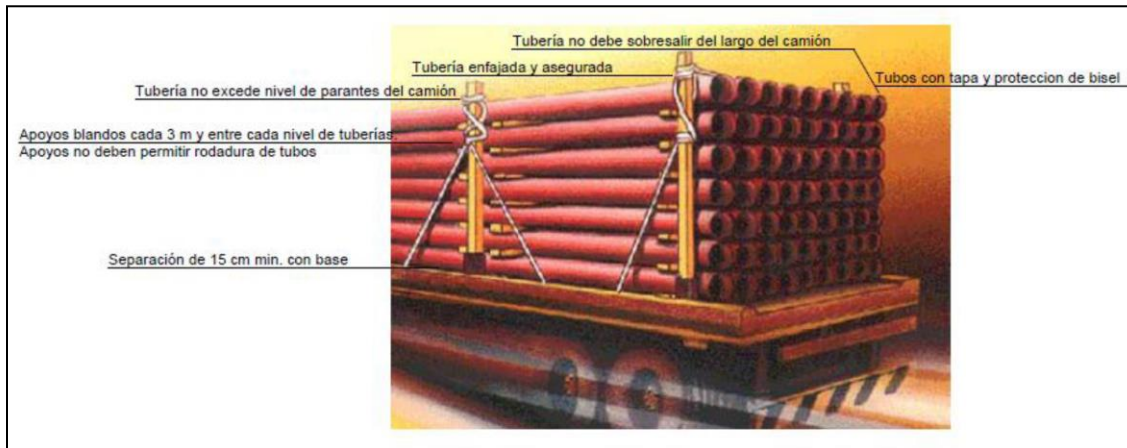



6.2 ALMACENAJE DE TUBERÍA



7. SOLDADURA POR ELECTROFUSIÓN
5.1. CORRECTA UNIÓN A ENCHUFE POR *ELECTROFUSIÓN*

Figura 1. Aspecto de una correcta unión a enchufe por *electrofusión*.

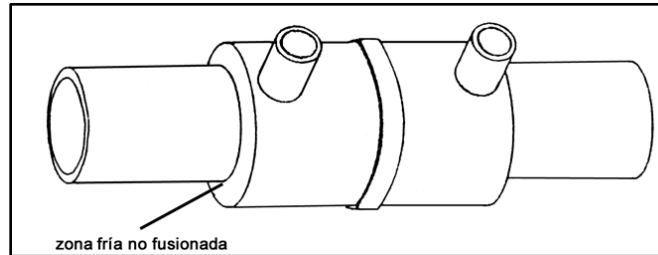

5.2. INCORRECTA UNIÓN A ENCHUFE POR *ELECTROFUSIÓN*

Figura 2. Penetración inadecuada de los tubos en el accesorio.



Figura 3. Penetración incompleta de uno de los tubos en el accesorio.





Figura 4. Áreas sin fusionar debido a superficies sin preparación adecuada.

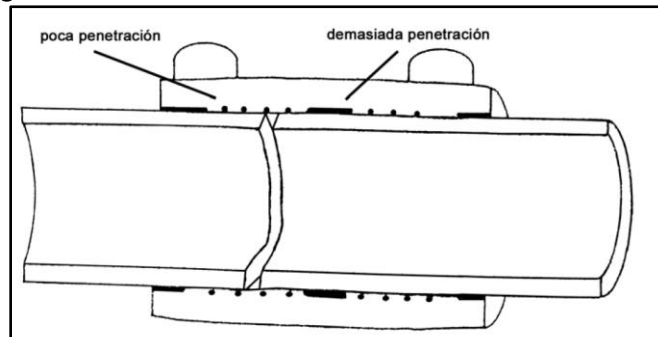

Figura 5. Alineación defectuosa.

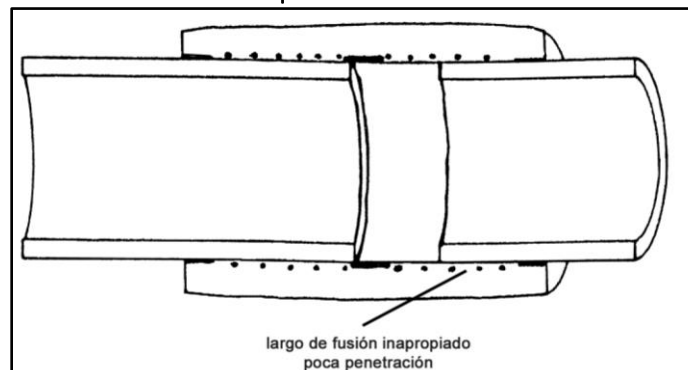
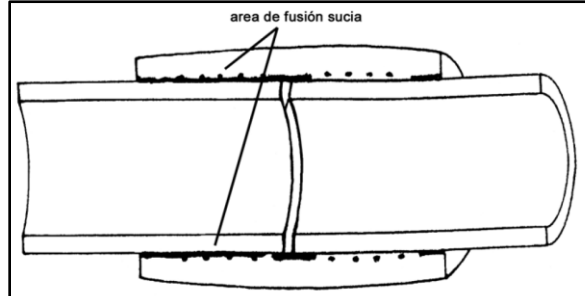
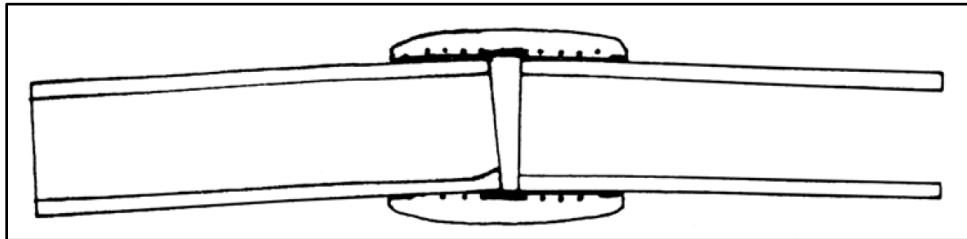

Fecha: 06 de septiembre de 2019